



PV SYSTEMS

PV SYSTEMS

- PV generator
 - Mismatch and/or shading
 - Temperature effect
- Energy storage
 - Lead acid batteries
- Power conditioning and control
 - Charge controller
 - Inverter

PV SYSTEMS

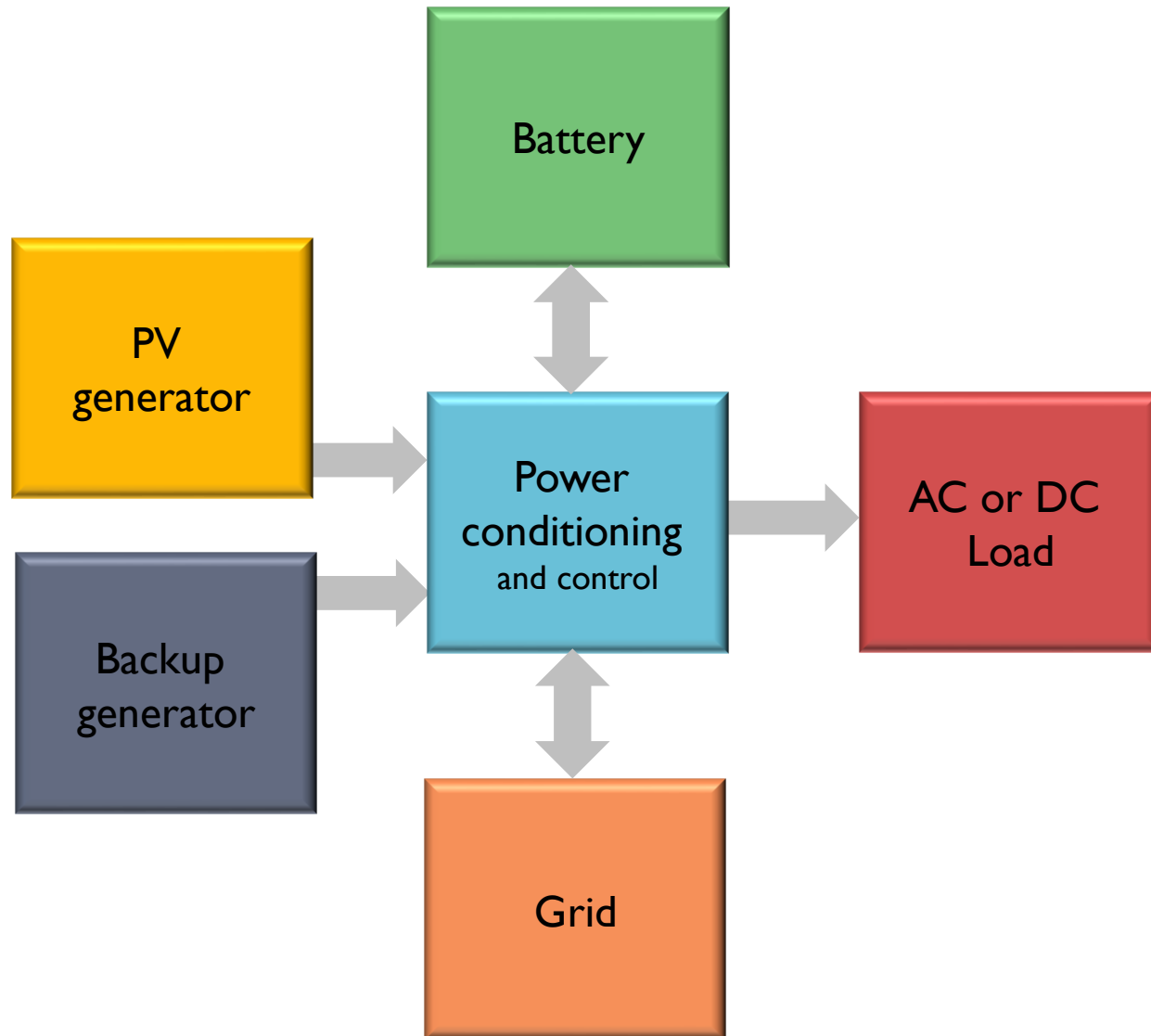

PV SYSTEMS

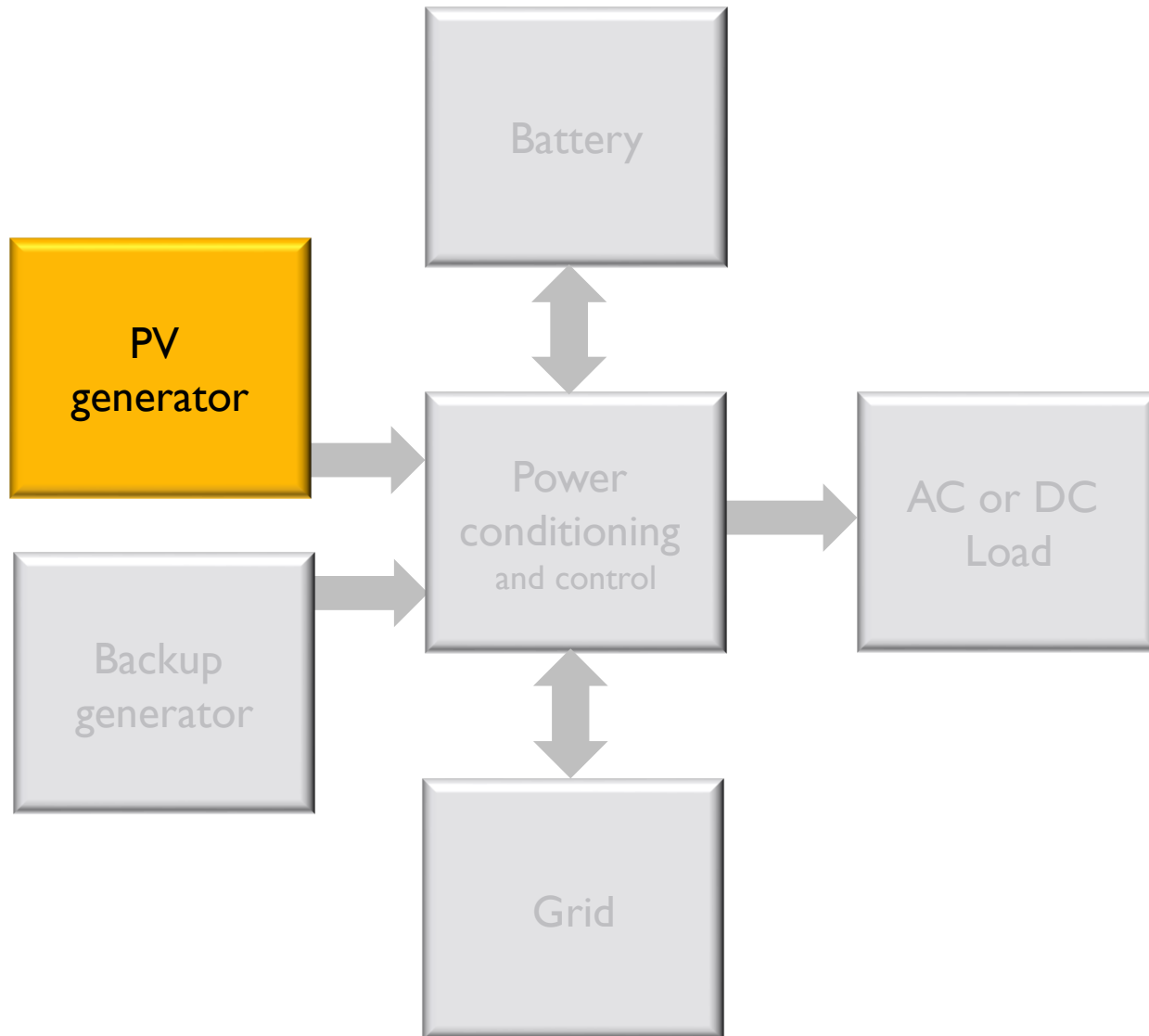

PV SYSTEMS: solar module

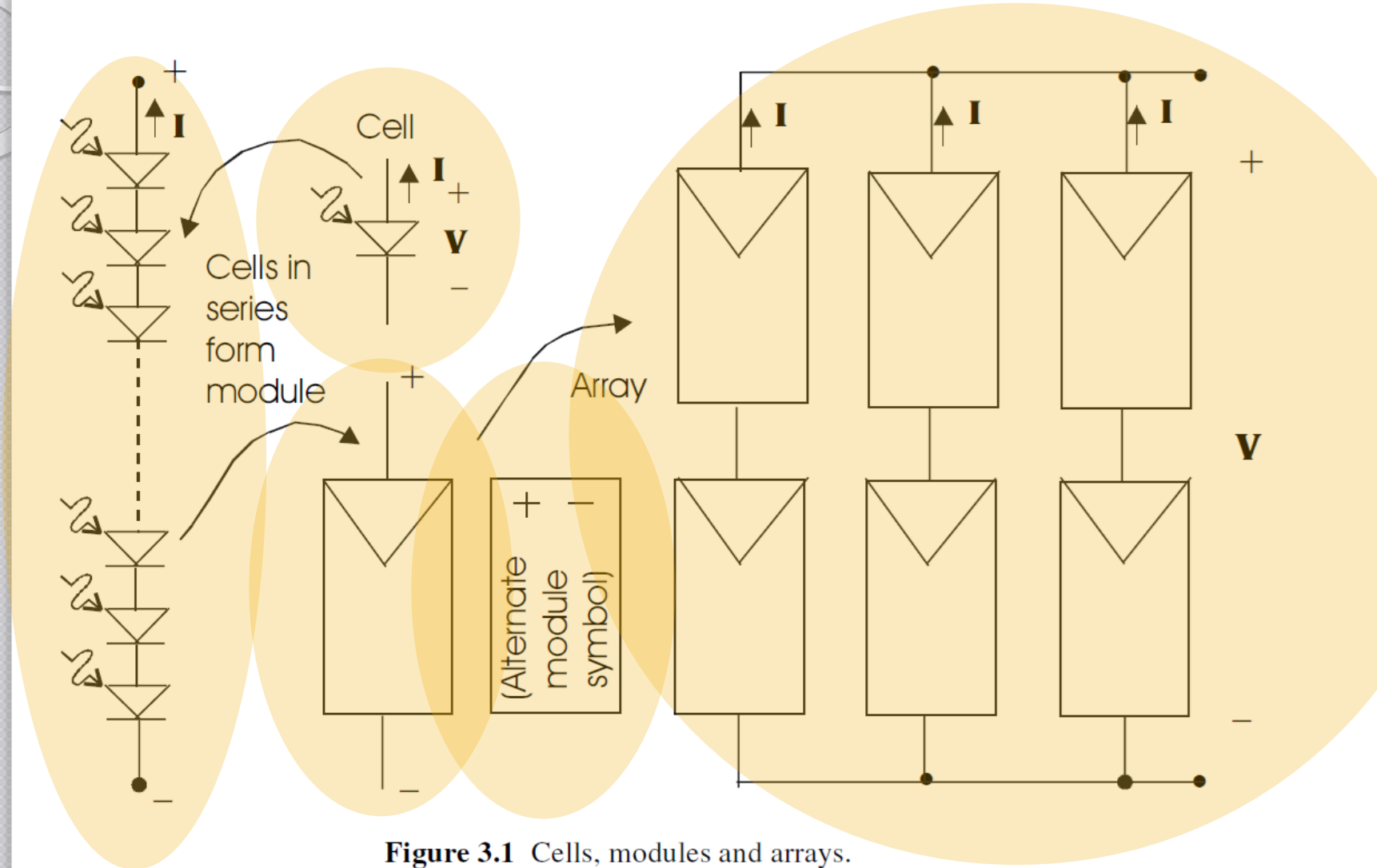

Figure 3.1 Cells, modules and arrays.

PV SYSTEMS: solar module

In a module, solar cells usually connected in **series**.

- For a 12V battery:
 - Not optimum irradiation: 16V
 - Fill factor (80%): 20V
 - Each cell (0.6V) $\times n = 20V$
 $n = 33-36$ cells in series

PV SYSTEMS: solar module

When the PV module is not illuminated

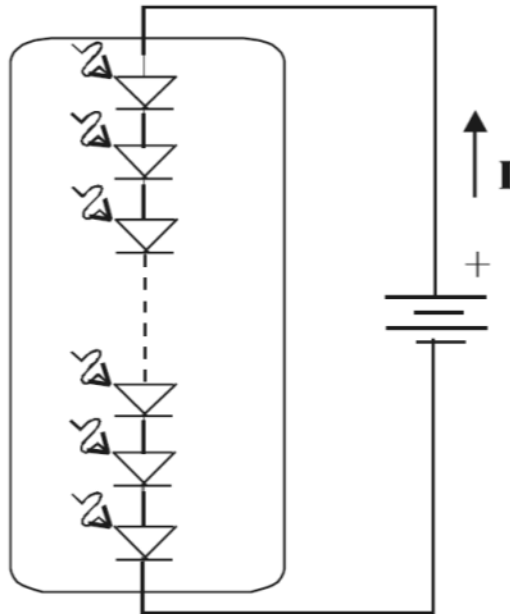

Example:

33 cells

Saturation current: 10-10A

Battery: 12.8V

Voltage across each cell: $12.8/33=388\text{mV}$

Current: 0.32mA (use diode equation)

The battery will discharge during nighttime!

More cells in series: lower voltage across each cell, lower reverse current

PV SYSTEMS: solar module

When the PV module is not illuminated

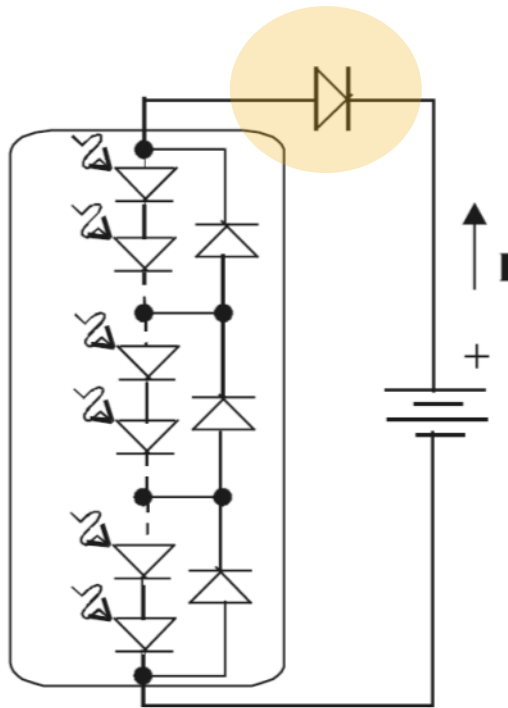

Example:

33 cells

Saturation current: 10-10A

Battery: 12.8V

Voltage across each cell: $12.8/33=388\text{mV}$

Current: 0.32mA (use diode equation)

The battery will discharge during nighttime!

More cells in series: lower voltage across each cell, lower reverse current

Or use a **blocking diode**

PV SYSTEMS: solar module

When **one cell** is not illuminated?

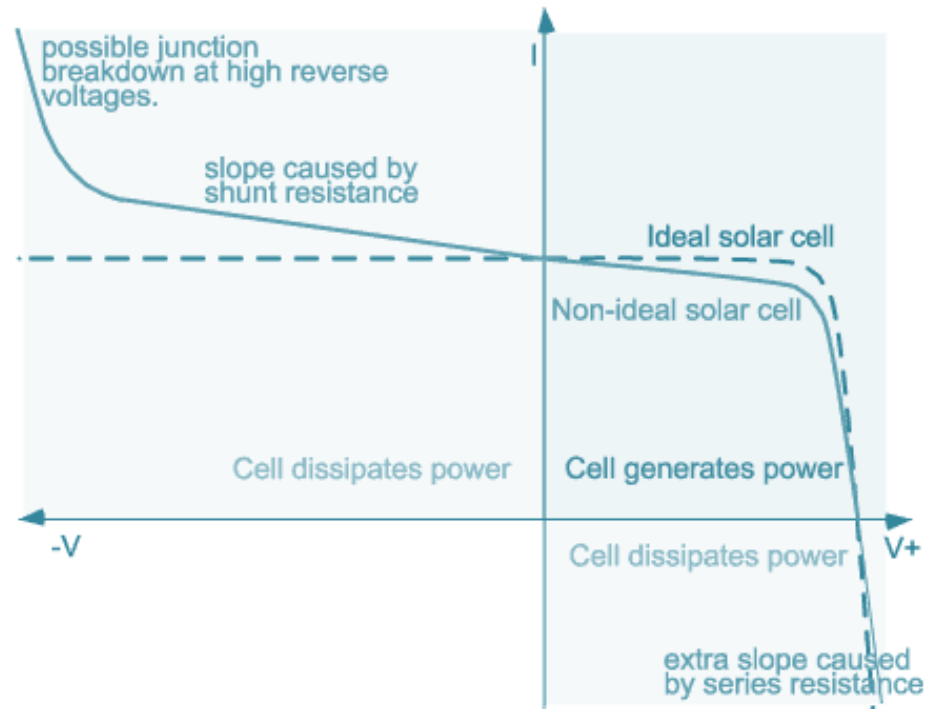

PV SYSTEMS: solar module

When **one cell** is not illuminated?

Matched solar cells in series:

Cells are in short circuit so:

- Current = I_{sc}
- Voltage = 0V

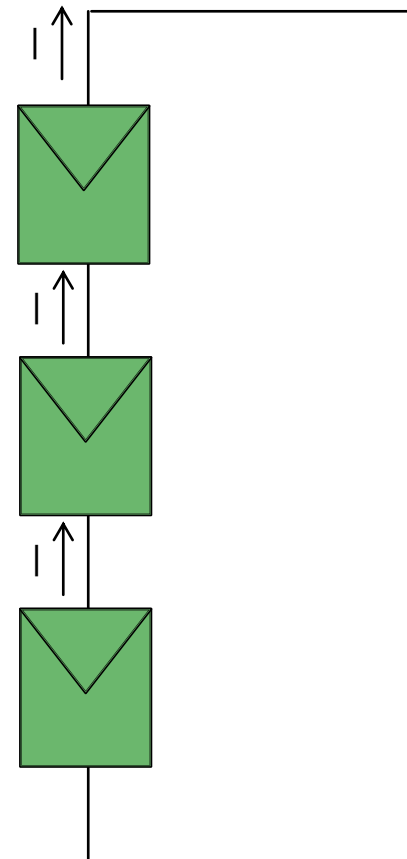

PV SYSTEMS: solar module

When **one cell** is not illuminated?

Mismatched solar cells:

Because series connection, current is dominated by 'poor' cell: $I = I_{sc2} (< I_{sc1})$

The 3 cells are short-circuited so the total voltage is still 0V.

'Poor' cell becomes reverse bias and dissipates 'extra' current. If string is long one will get above breakdown voltage and then **hotspot!**

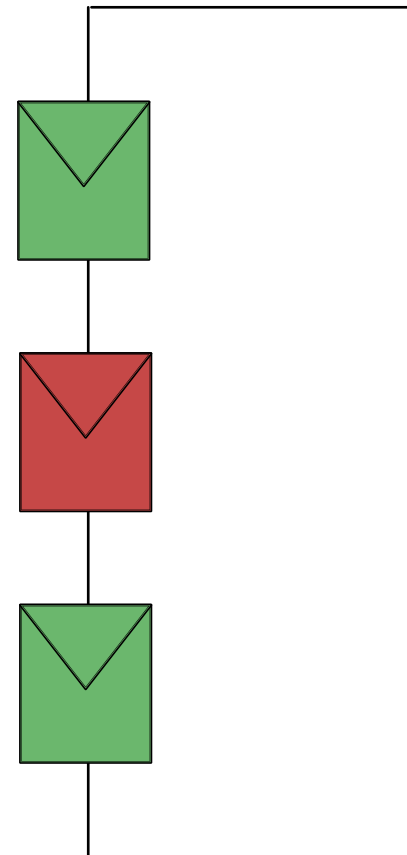

PV SYSTEMS: solar module

When **one cell** is not illuminated?

Matched solar cells, using **bypass diode**

No effect.

Bypass diodes are reversed bias so no current flow through bypass.

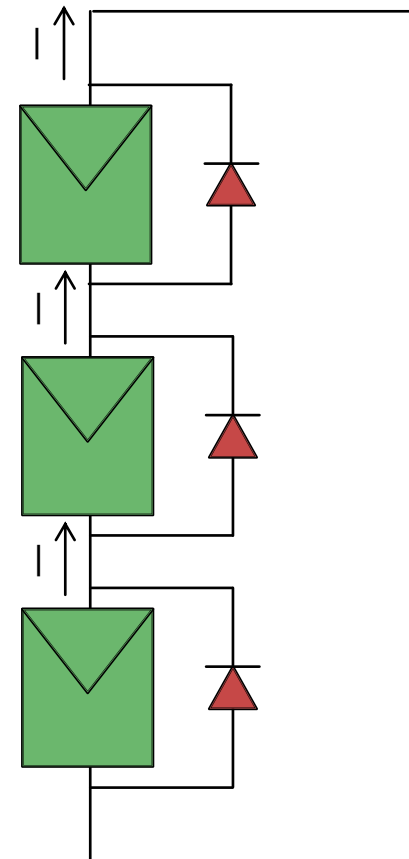

PV SYSTEMS: solar module

When **one cell** is not illuminated?

Mismatched solar cells, using **bypass diode**

'Good' cells are forward bias and shaded cell is reverse bias.

Bypass diode of the good cells are reversed biased (no effect).

Bypass diode of the shaded cell is forward bias and conducts current. Voltage drop is only -0.5V , avoiding any hotspots.

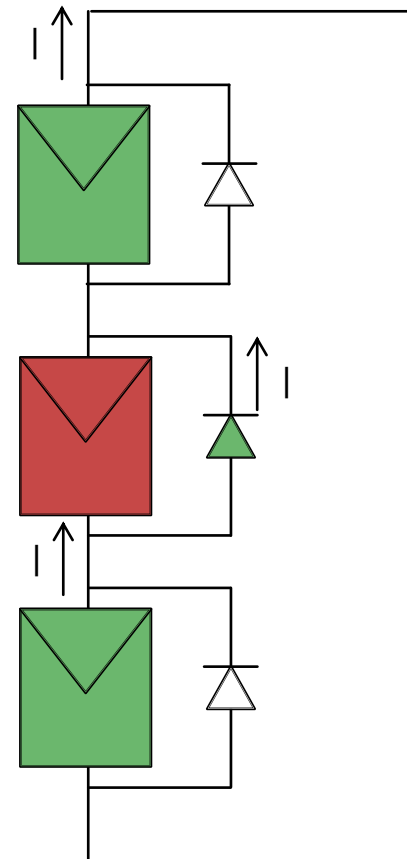

PV SYSTEMS: solar module

Blocking and bypass diodes!

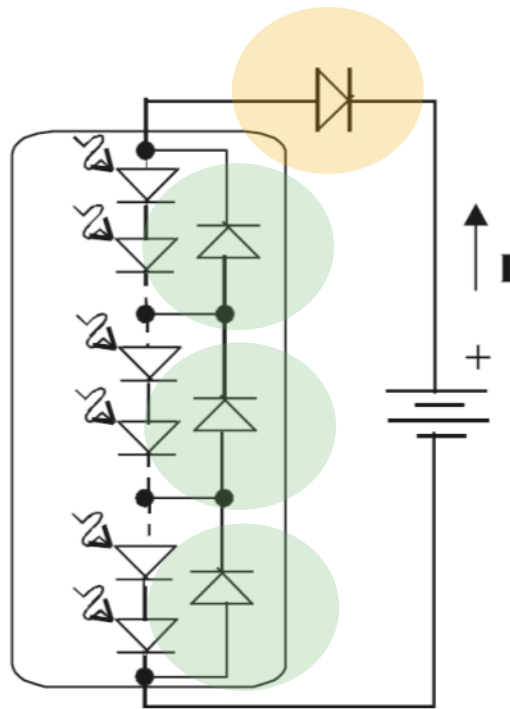

PV SYSTEMS: solar module

- Module parameters are defined for **standard conditions**
 - Irradiance: 1 kW/m^2
 - Spectral distribution: AM1.5
 - Cell temperature: 25°C

PV SYSTEMS: solar module

- V_{oc} sensitive to cell temperature:

$$\frac{dV_{oc}}{dT} = -2.3 \times n \quad (mV / ^\circ C)$$

- **Normal Operating Cell Temperature (NOCT)**

- Irradiance: 0.8 kW/m^2
 - Spectral distribution: AM1.5
 - Ambient temperature: 25°C
 - Wind speed: $< 1 \text{ m/s}$
- The **cell temperature** T_c for a given ambient temperature T_a and irradiance G (kW/m^2) is:

$$T_c - T_a = \frac{NOCT - 20}{0.8} G$$

PV SYSTEMS: solar module

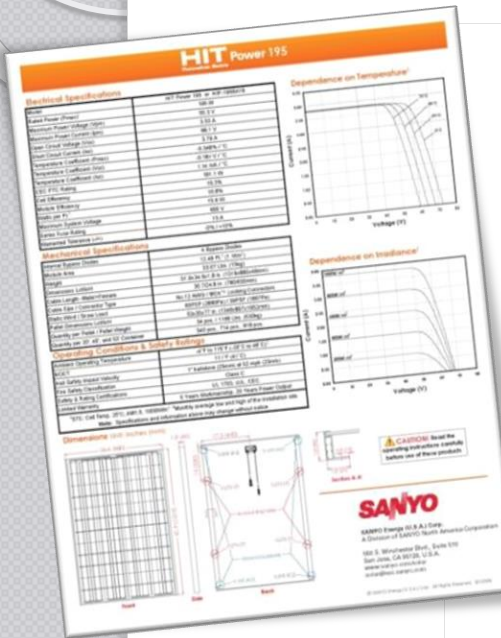

Electrical Specifications

Model	HIT Power 195 or HIP-195BA19
Rated Power (Pmax) ¹	195 W
Maximum Power Voltage (Vpm)	55.3 V
Maximum Power Current (Ipm)	3.53 A
Open Circuit Voltage (Voc)	68.1 V
Short Circuit Current (Isc)	3.79 A
Temperature Coefficient (Pmax)	-0.348% / °C
Temperature Coefficient (Voc)	-0.189 V / °C
Temperature Coefficient (Isc)	1.98 mA / °C
CEC PTC Rating	181.1 W
Cell Efficiency	19.3%
Module Efficiency	16.8%
Watts per Ft. ²	15.6 W
Maximum System Voltage	600 V
Series Fuse Rating	15 A
Warranted Tolerance (-/+)	-0% / +10%

PV SYSTEMS: solar module

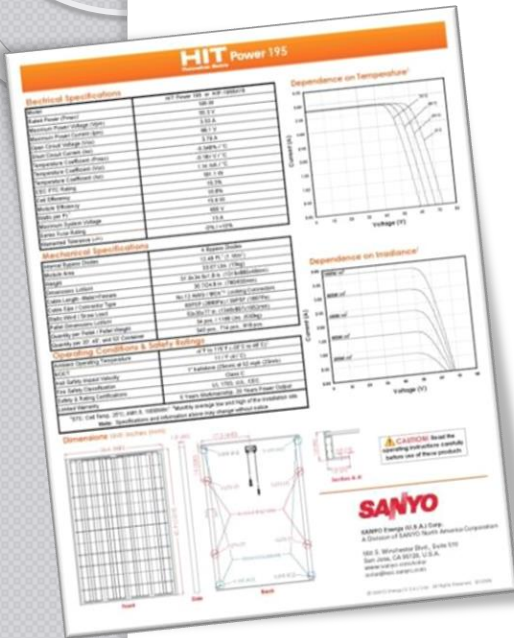

Dependence on Irradiance¹

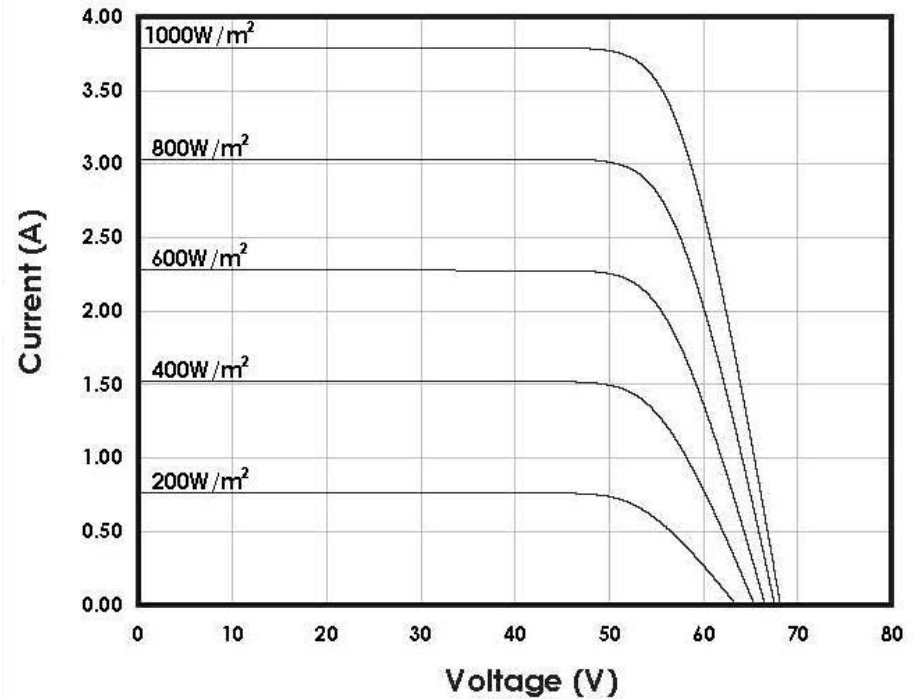

PV SYSTEMS: solar module

HIT Power 195

Electrical Specifications

Rated Power (P _{max})	195 W
Maximum Power Voltage (V _{mp})	33.7 V
Maximum Power Current (I _{mp})	5.79 A
Open-Circuit Voltage (V _{oc})	40.0 V
Short-Circuit Current (I _{sc})	6.00 A
Temperature Coefficient (P _{max})	-0.45 %/°C
Temperature Coefficient (V _{oc})	1.90 %/°C
Temperature Coefficient (I _{sc})	0.05 %/°C
Cell Efficiency	19.3 %
Module Efficiency	18.0 %
Maximum System Voltage	600 V
Module Size (mm)	1650 x 990
Weight (kg)	10.5

Mechanical Specifications

Number of Solar Cells	60 (6x10)
Cell Size (mm)	165 x 99
Module Length (mm)	1650
Module Width (mm)	990
Module Area (m ²)	1.6335
Module Weight (kg)	10.5
Module Thickness (mm)	35
Module Tilt Angle	0°
Module Ingress Protection (IP)	IP65
Module Operating Temperature Range	-40°C to +85°C
Module Storage Temperature Range	-40°C to +125°C
Module Shock Resistance	2000 g, 11ms, 1000 cycles
Module Vibration Resistance	10g, 10-2000 Hz, 6hrs
Module Wind Load Resistance	2400 Pa
Module Snow Load Resistance	5400 Pa
Module Hail Resistance	25mm, 23m/s, 1000 impacts

Dimensions (mm)

CAUTION Avoid the operating temperature limits before use of these products.

SANYO

SANYO Energy (U.S.A.) Corp.
A Division of SANYO North American Corporation
3845 S. Winchester Blvd., Suite 500
San Jose, CA 95128, U.S.A.
www.sanyo.com/usa
info@sanyo.com/usa

Dependence on Temperature¹

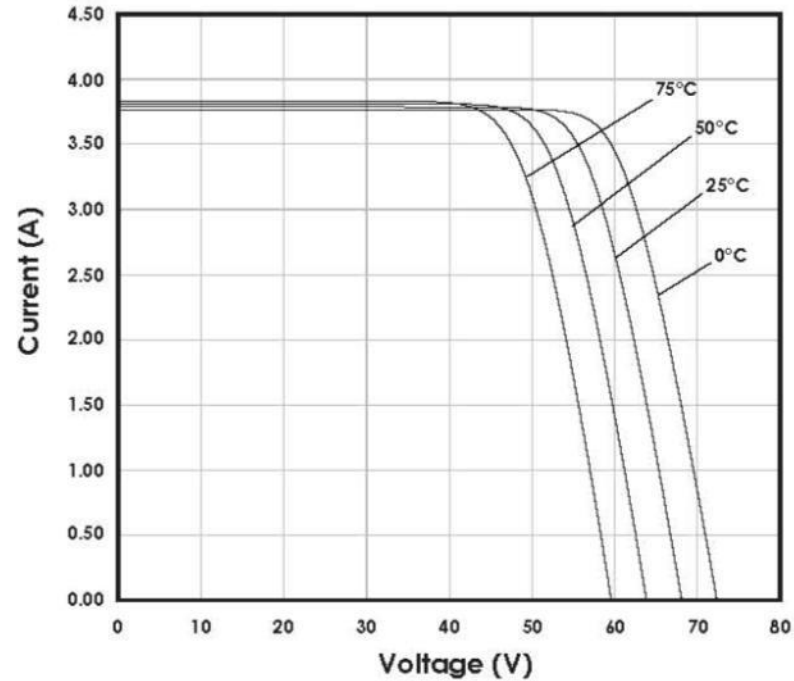

PV SYSTEMS: solar module

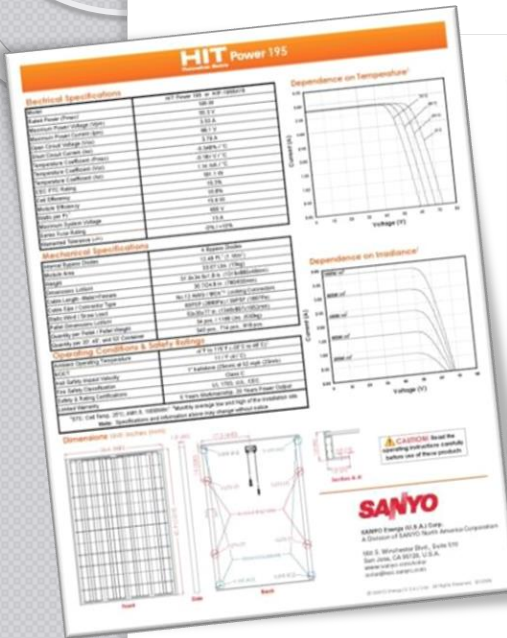

Mechanical Specifications

Internal Bypass Diodes	4 Bypass Diodes
Module Area	12.49 Ft. ² (1.16m ²)
Weight	33.07 Lbs. (15kg)
Dimensions LxWxH	51.9x34.6x1.8 in. (1319x880x46mm)
Cable Length -Male/+Female	30.7/24.8 in. (780/630mm)
Cable Size / Connector Type	No.12 AWG / MC4™ Locking Connectors
Static Wind / Snow Load	60PSF (2880Pa) / 39PSF (1867Pa)
Pallet Dimensions LxWxH	53x35x77 in. (1346x897x1952mm)
Quantity per Pallet / Pallet Weight	34 pcs. / 1166 Lbs. (530kg)
Quantity per 20', 40', and 53' Container	340 pcs., 714 pcs., 918 pcs.

Operating Conditions & Safety Ratings

Ambient Operating Temperature	-4°F to 115°F (-20°C to 46°C) ²
NOCT	113°F (45°C)
Hail Safety Impact Velocity	1" hailstone (25mm) at 52 mph (23m/s)
Fire Safety Classification	Class C
Safety & Rating Certifications	UL 1703, cUL, CEC
Limited Warranty	5 Years Workmanship, 20 Years Power Output

¹STC: Cell Temp. 25°C, AM1.5, 1000W/m² ²Monthly average low and high of the installation site.

Note: Specifications and information above may change without notice.

PV SYSTEMS: solar module

HIT Power 195

Electrical Specifications

Parameter	Value
Rated Power (P _{max})	195 W
Open-Circuit Voltage (V _{oc})	37.7 V
Maximum Power Voltage (V _{mp})	31.2 V
Maximum Power Current (I _{mp})	6.25 A
Short-Circuit Current (I _{sc})	7.0 A
Temperature Coefficient (P _{max})	-0.45 %/°C
Temperature Coefficient (V _{oc})	-0.23 %/°C
Temperature Coefficient (I _{sc})	0.05 %/°C
Cell Efficiency	19.3 %
Module Efficiency	18.5 %
Maximum System Voltage	600 V
Series Fuse Rating	25 A

Dependence on Temperature

Mechanical Specifications

Parameter	Value
Module Weight	11.4 kg (25.1 lb)
Module Depth	30 mm (1.18 in.)
Module Length	1650 mm (65.0 in.)
Module Width	992 mm (39.1 in.)
Module Area	1.64 m ² (17.6 ft ²)
Module Area (with frame)	1.78 m ² (19.1 ft ²)
Module Area (with frame and cable)	1.85 m ² (20.0 ft ²)
Module Area (with frame and cable, including junction box)	1.92 m ² (20.8 ft ²)
Module Area (with frame and cable, including junction box and mounting holes)	1.98 m ² (21.4 ft ²)

Dependence on Irradiance

Dimensions (mm)

SANYO
 SANYO Energy U.S.A. Corp.
 A Division of SANYO North American Corporation
 3845 S. Winchester Blvd., Suite 500
 San Jose, CA 95128, U.S.A.
 www.sanyo.com
 sanyo@usa.sanyo.com

Dimensions Unit: inches (mm)

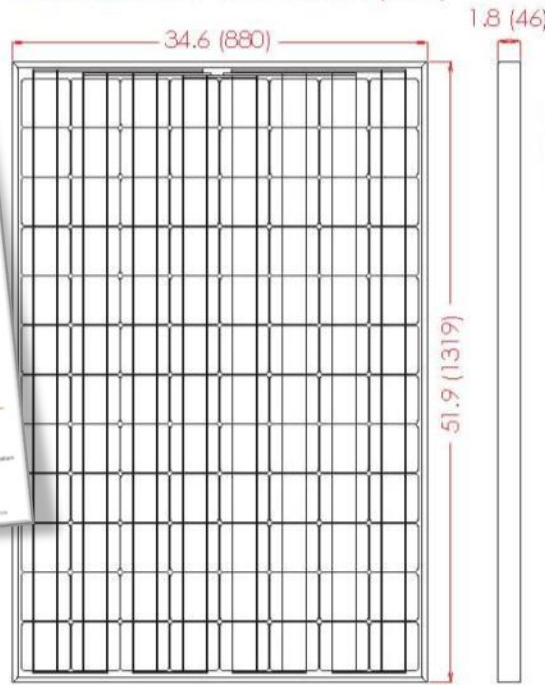

Front

Side

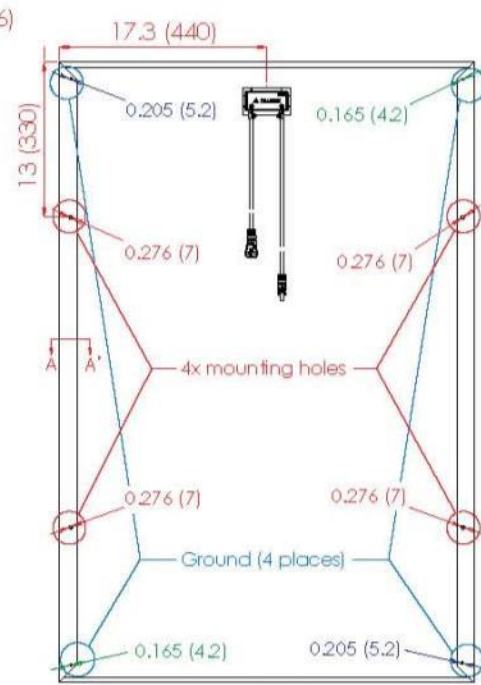

Back

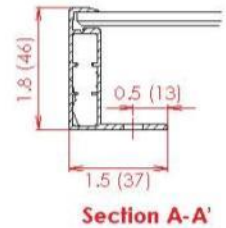

PV SYSTEMS

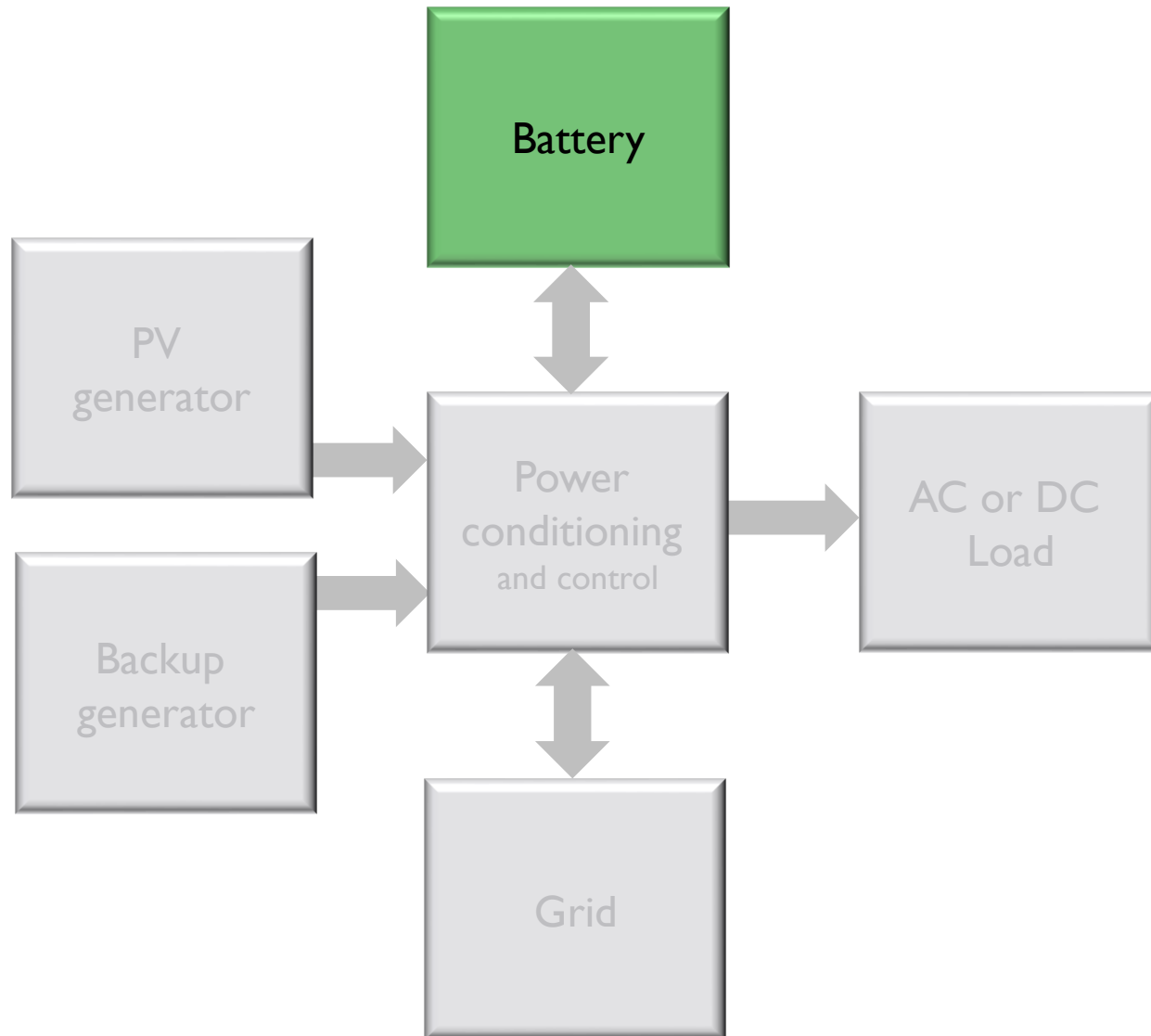

PV SYSTEMS: storage

Energy stored	Technology	Remarks
Mechanical	Pumped water	PV pumping; or Large-scale storage solution
	Compressed air	Large-scale storage solution
	Flywheel	Under development for small (short) systems
Electromagnetic	Electric current in superconducting ring	Potentially interesting for 'high temperature' superconductors
Chemical	Batteries	Most common for PV
	Hydrogen	Under development

PV SYSTEMS: storage

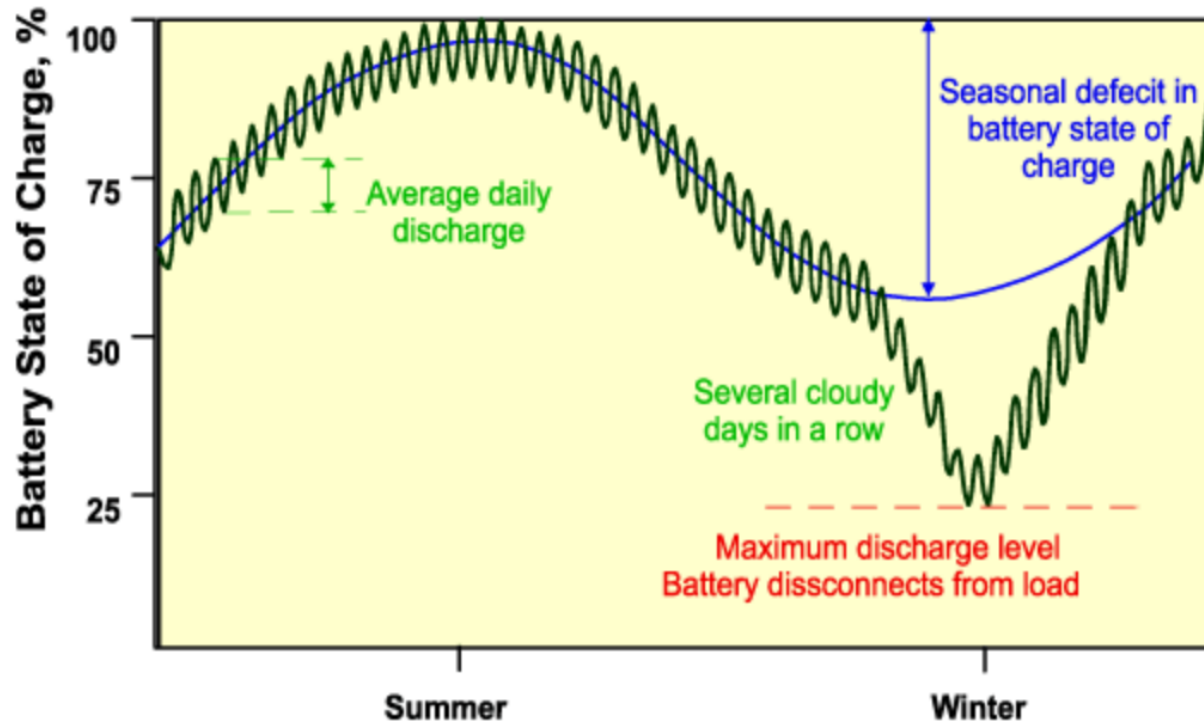

PV SYSTEMS: storage

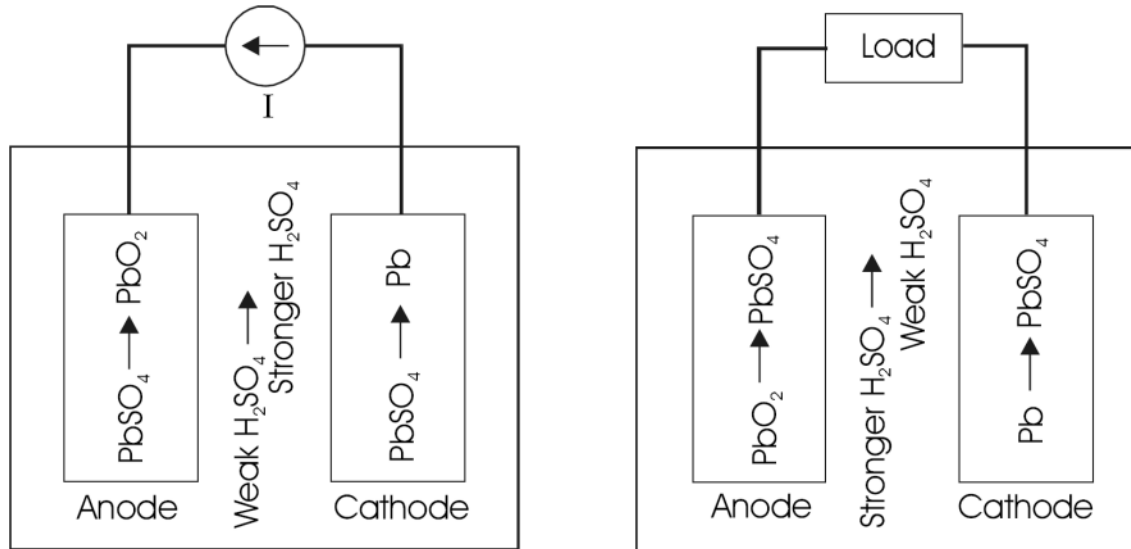

a. Charging process

b. Discharging process

CHARGING

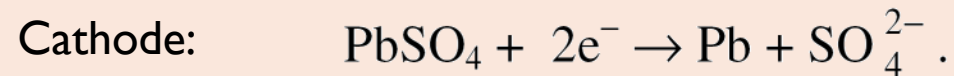
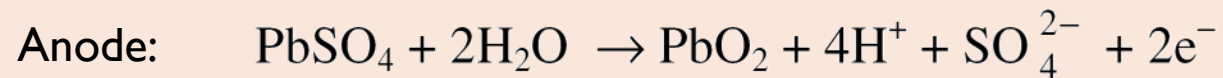

DISCHARGING

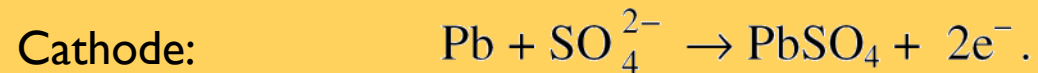

PV SYSTEMS: storage

- **Gassing** – when overcharged, hydrogen ions combine with free electrons and are converted into gaseous hydrogen
- **Sulphatation** – formation of large lead sulphate crystals at the plate
- **Stratification** – non-uniform electrolyte distribution
- **Electrode corrosion** – accelerated at higher temperatures

PV SYSTEMS: storage

AVOID OPERATION...	TO PREVENT...
High voltages during charge	Corrosion, water loss
Low voltages during discharge	Corrosion
Deep Discharge	Sulphation, dendrite growth
Extended period w/o fully charge	Sulphation
High temperature	All ageing processes
Stratification of the electrolyte	Sulphation
Very low charge current	Sulphation

PV SYSTEMS: storage

Charging/discharging should be reversible, but there are **losses**:

- Internal resistance loss (IR^2): lower performance for higher currents (also depends on operating temperature)
- Hydrogen escape = energy loss

Overall efficiency: **~90%**

PV SYSTEMS: storage

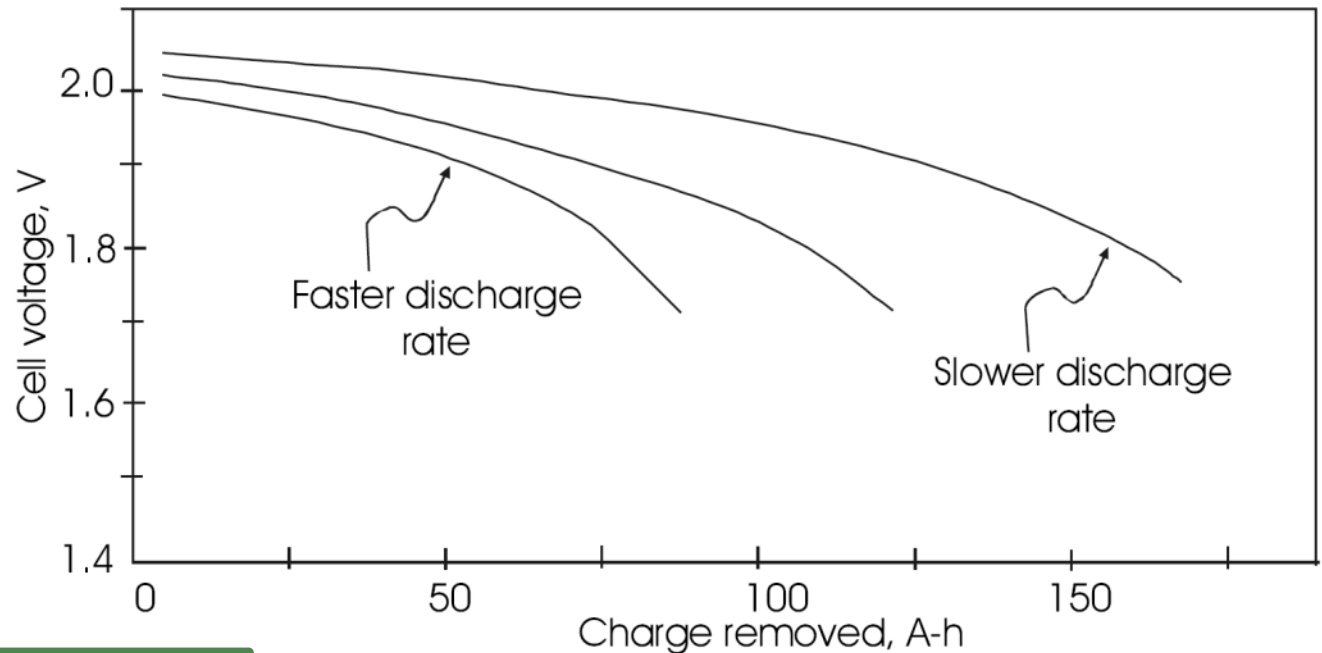

Higher C/x means
Higher currents thus
Higher heat losses and
Less useful energy

Battery capacity: C
Battery (dis)charge rate: C/x

PV SYSTEMS: storage

- Warm batteries are capable of storing more charge than cold batteries

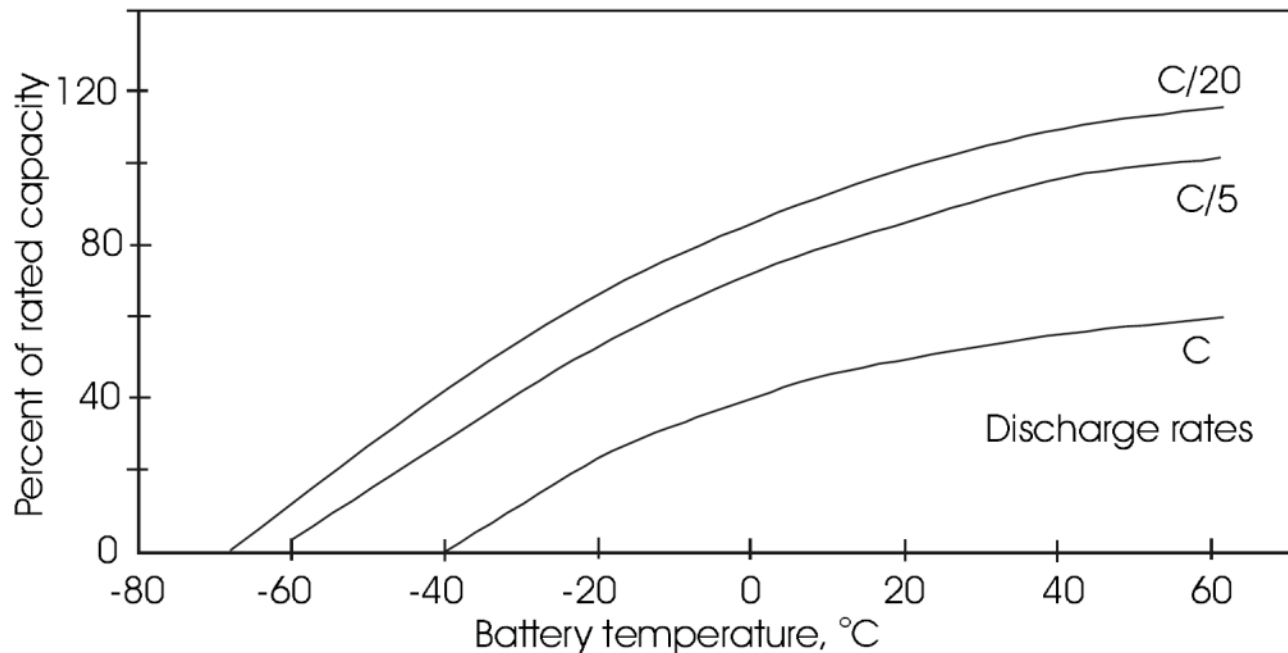
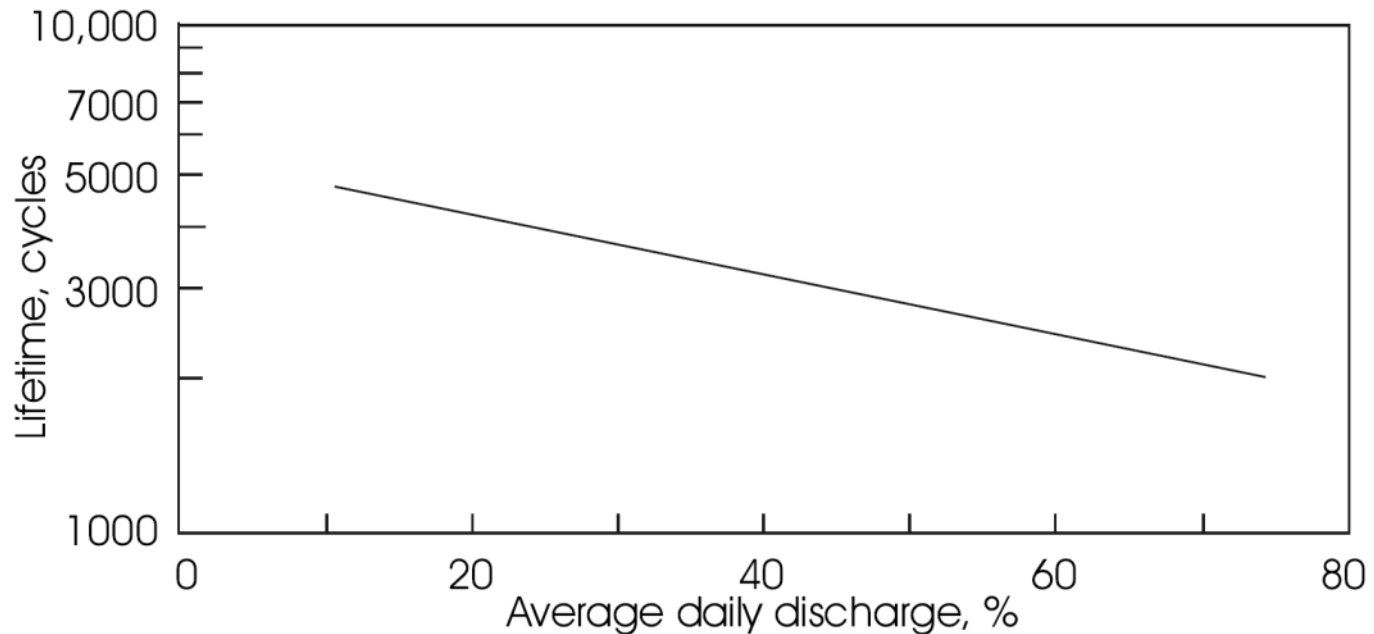

Figure 3.12 Effect of temperature and discharge rate on available energy from a lead-acid battery.

PV SYSTEMS: storage

- Lifetime sensitive to depth of discharge



Which is unfortunate for pv systems; either one changes batteries all the time or we need to oversize them!

Lead-acid battery lifetime in cycles vs. depth of discharge per cycle [1].

PV SYSTEMS: control

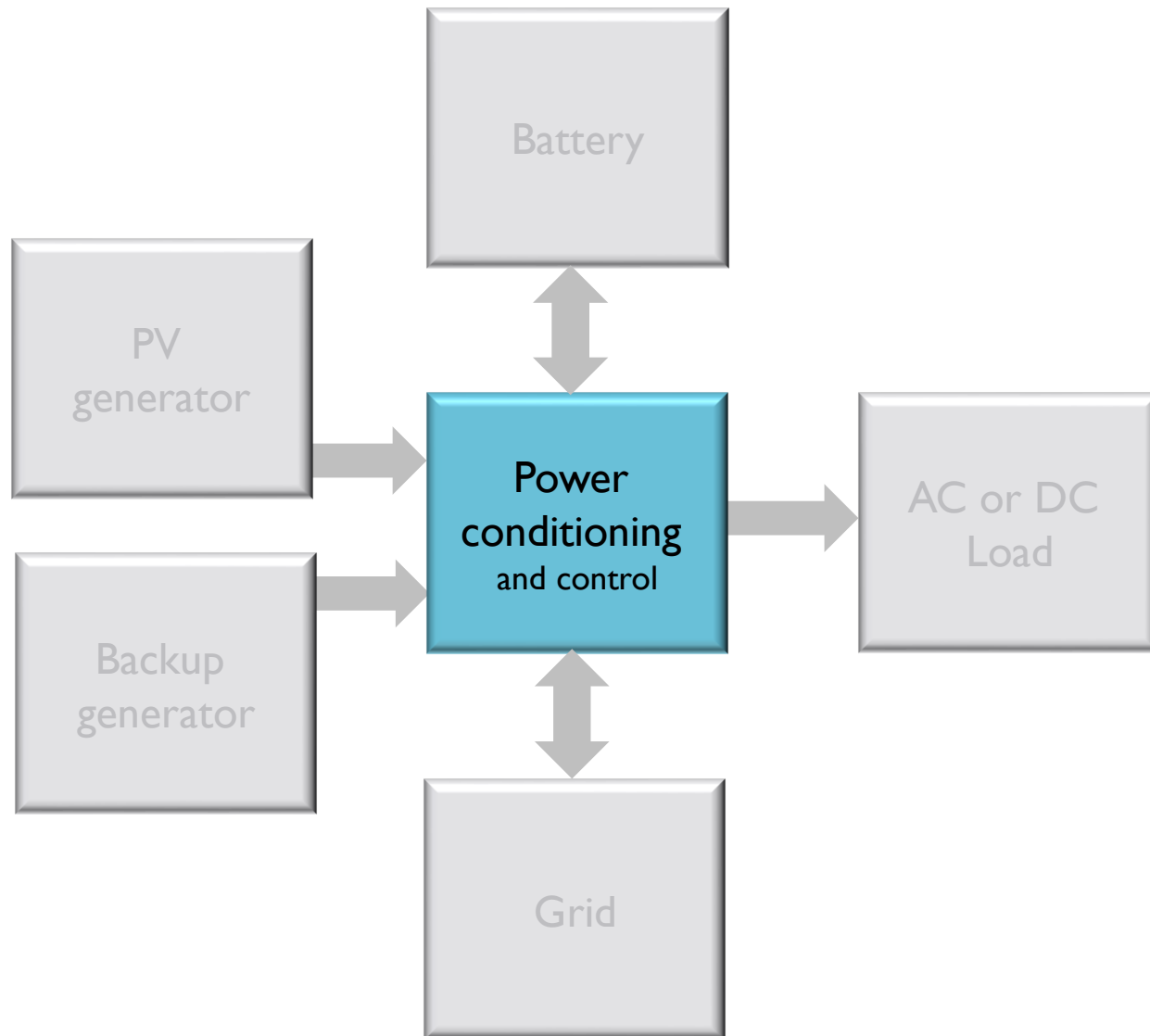

PV SYSTEMS: control

Charge regulator

- Load disconnect/reconnect voltage
 - User satisfaction vs battery lifetime
 - may accommodate warning signal (30' in advance) and/or "manual bypass" for special occasions*
- End-of-charge/Reposition voltage
 - full charge (high V) vs corrosion and water consumption (low V)
- Protection against reverse current leakage

PV SYSTEMS: control

- Adjusting the load to the PV system point of maximum power

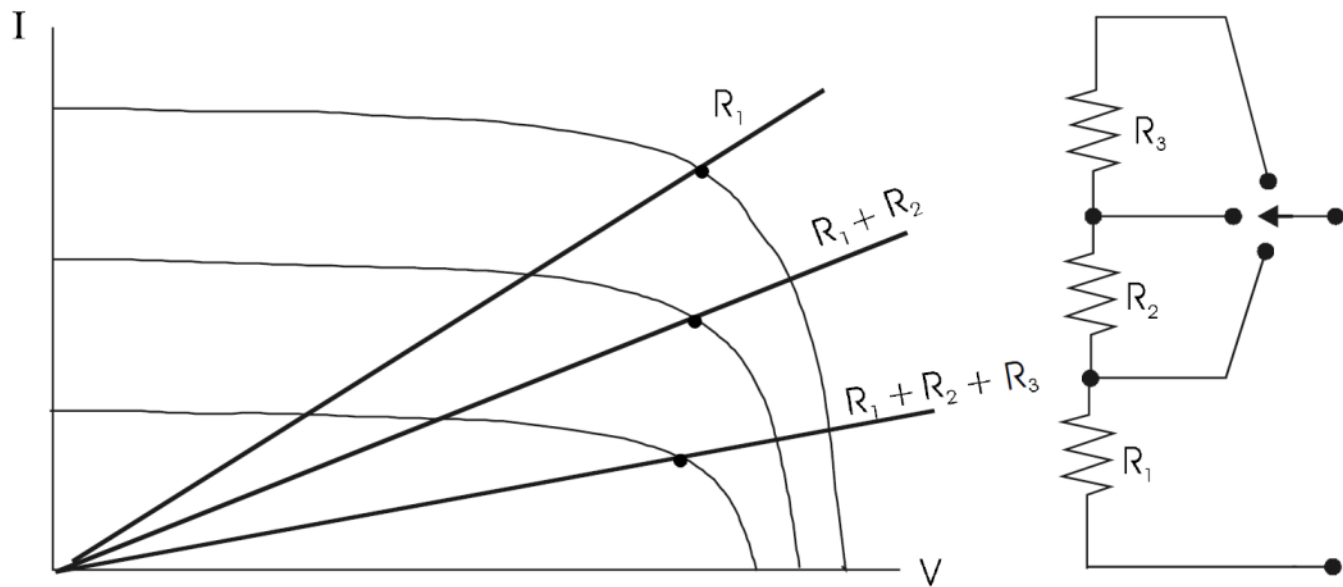

Figure 3.17 Varying a resistive load to track maximum power from a PV array.

PV SYSTEMS: control

Maximum power tracker

(DC/DC converter)

- Ensures maximum power transfer to load

$$V_R = \sqrt{P_{\max} R}$$

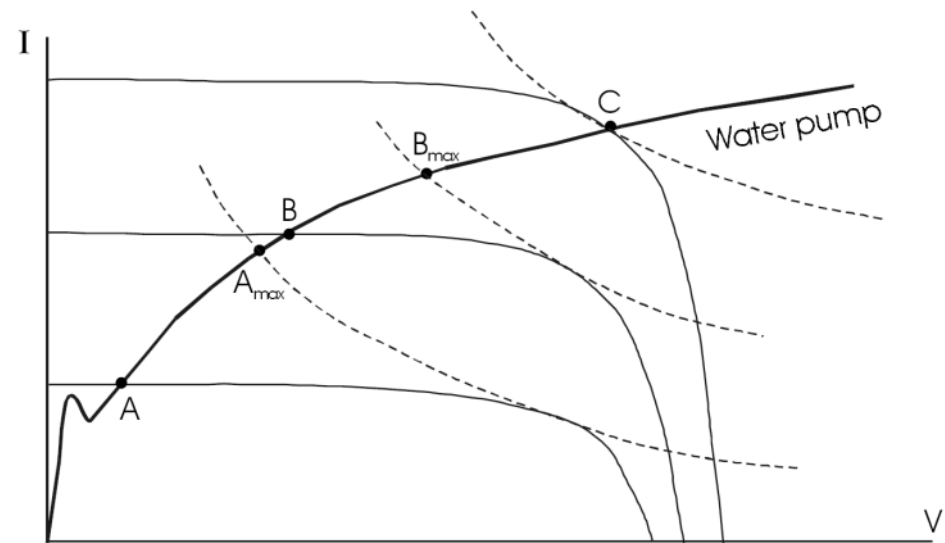

Figure 3.27 Pump and PV I-V characteristics, showing the need for use of MPT.

PV SYSTEMS: control

Inverter

(DC/AC converter)

- **Variable frequency** for PV pumping systems
- **Self-commutating fixed frequency** for isolated distribution grid
- **Line-commutated fixed frequency** for grid connection applications

PV SYSTEMS: control

Inverter

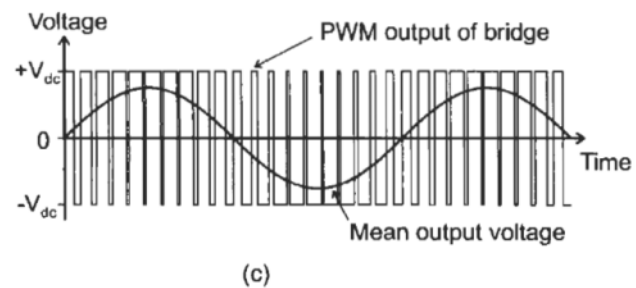
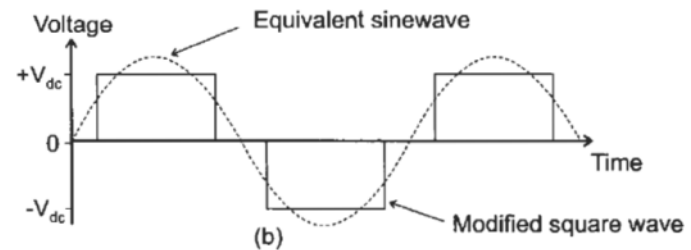
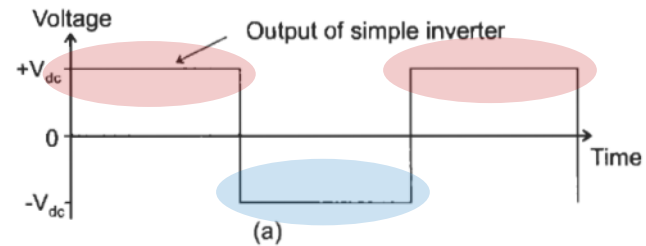
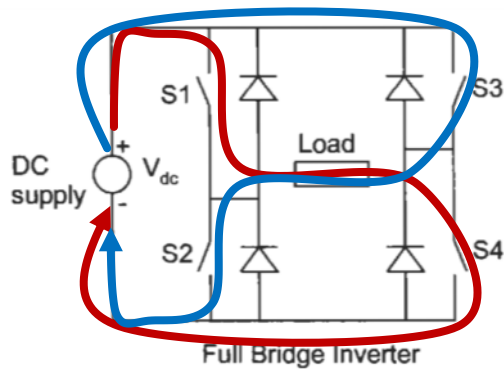

PV SYSTEMS: control

Inverter

- Inverter efficiency: $\eta = P_{AC} / P_{DC}$

To make comparison of different inverters and/or inverters that are operating under different climatic conditions possible:

$$\begin{aligned}\eta_{\text{EURO}} = & 0.03 \times \eta_{5\%} \\ & + 0.06 \times \eta_{10\%} \\ & + 0.13 \times \eta_{20\%} \\ & + 0.10 \times \eta_{30\%} \\ & + 0.48 \times \eta_{50\%} \\ & + 0.20 \times \eta_{100\%}\end{aligned}$$

(Efficiency index = percent of rated power)

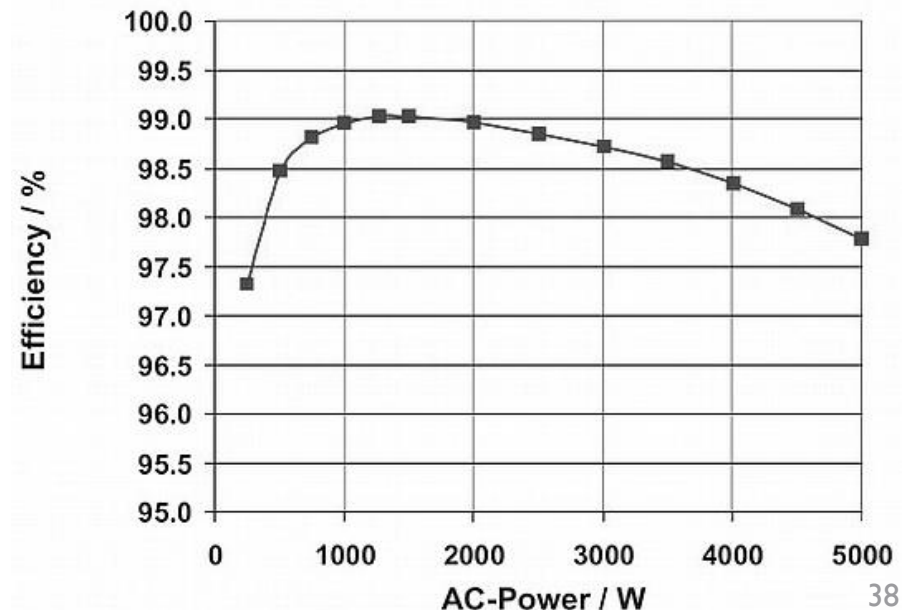

PV SYSTEMS: control

SMART MODULES

Goal: reduce system inefficiencies, maximizing electricity production

Added components increase power electronic costs and risk of failure

PV SYSTEMS: control

SMART MODULES

System inefficiencies

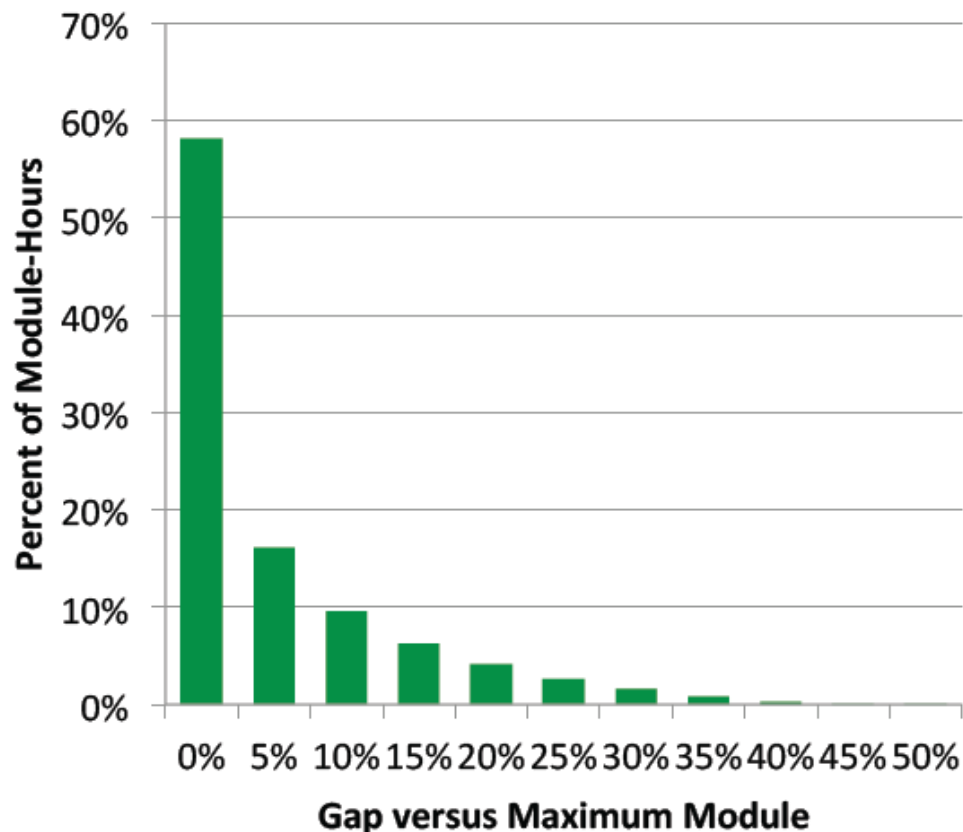

Mismatch from clouds

Not all modules in the same string are receiving the same irradiation.

On average it may reach 15% variation.

PV SYSTEMS: control

SMART MODULES

System inefficiencies

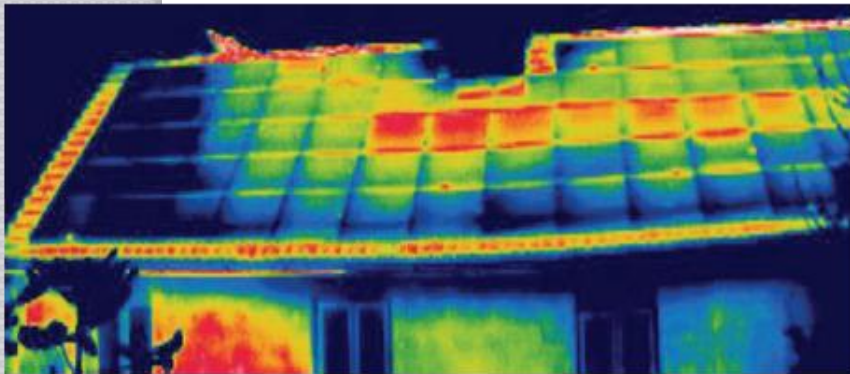

Mismatch from temperature

Not all modules at same temperature.

On average it reaches 4-7°C.

Not uniform ageing.
Some modules show faster degradation than others.

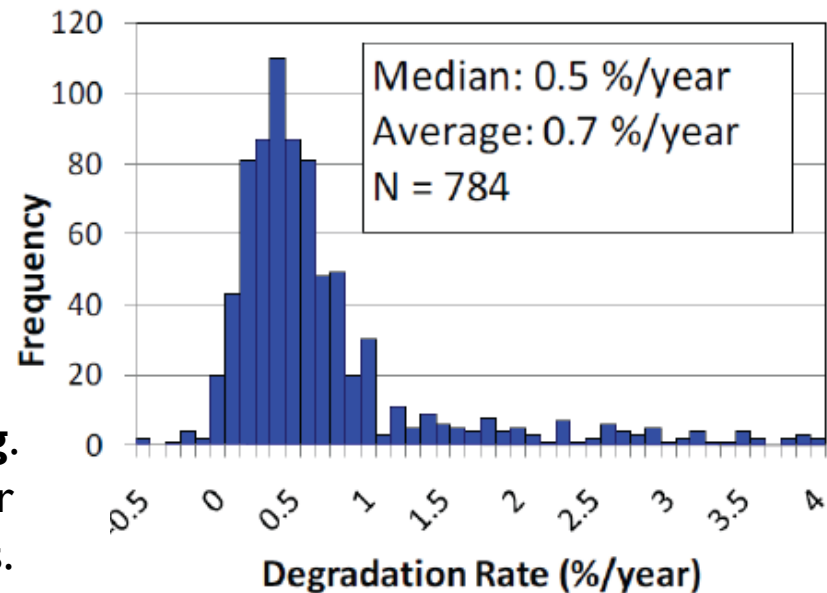

PV SYSTEMS: control

SMART MODULES

System inefficiencies

'Smart' modules can increase roof coverage

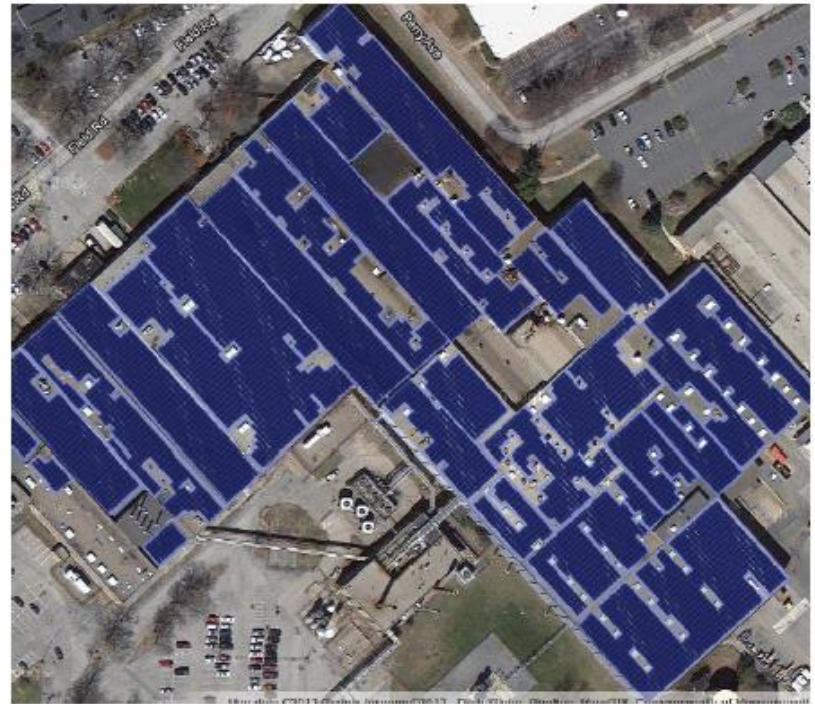
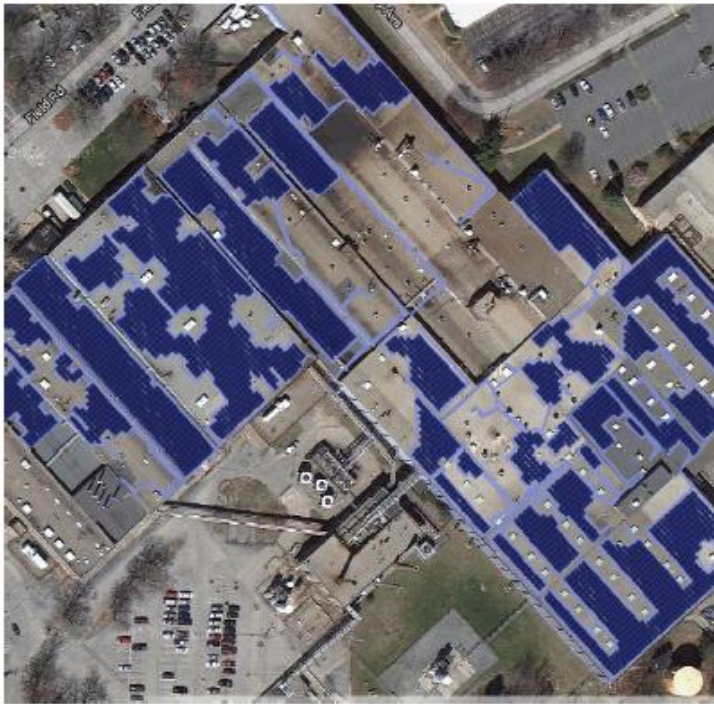

PV SYSTEMS: control

SMART MODULES

Power optimizers

25kW, Traditional System Design

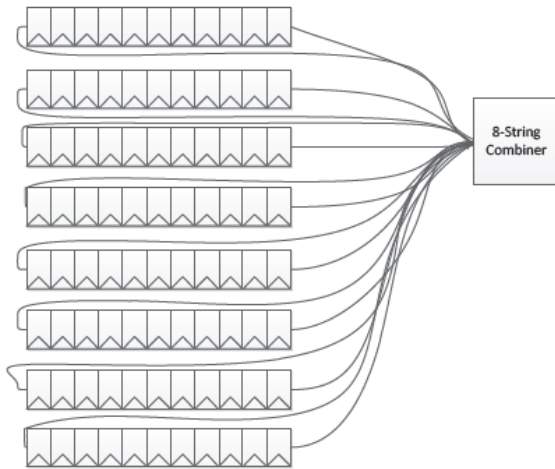

25kW with Tigo Energy® Smart-Curve

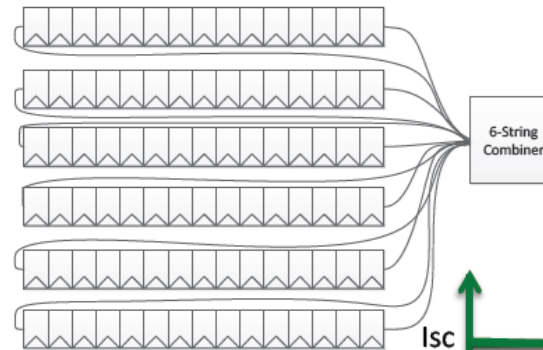

Fewer strings (~30%!), since maximum input voltage to inverter is limited.
Less cabling, less inverters.

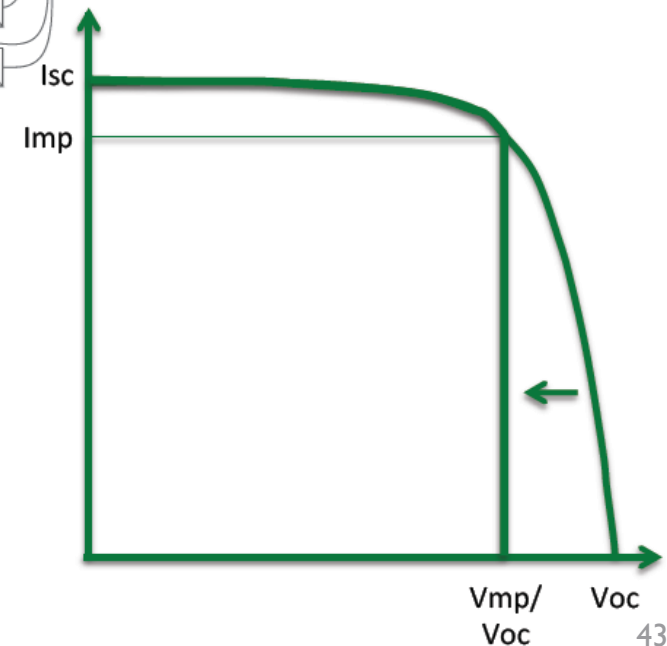

PV SYSTEMS: control

SMART MODULES

Micro-inverters

PV module becomes AC device.

Easier installation.

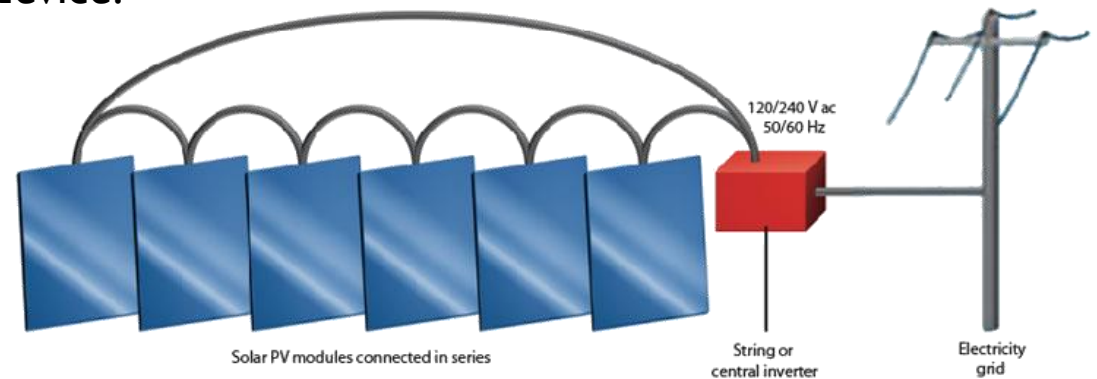

Figure 1. In conventional string architectures, the poorest performing solar module limits the output of the whole system as the domino effect can knock out all of the string inverters.

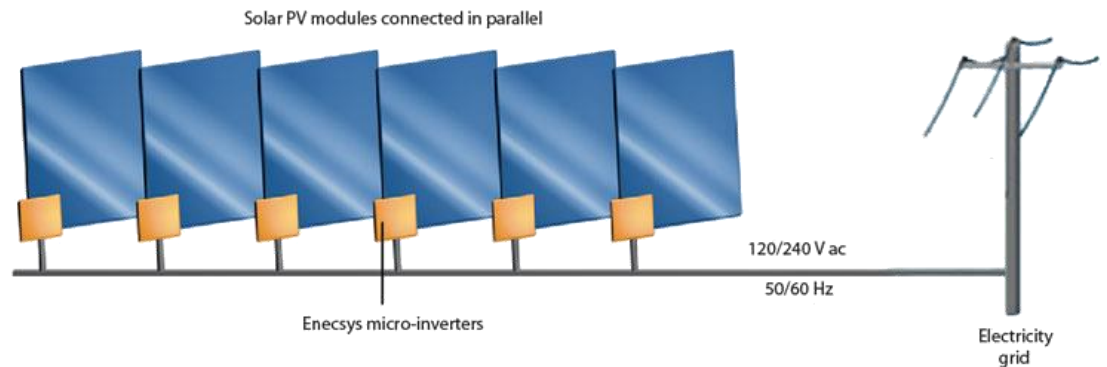

Figure 2. An Enecsys micro-inverter-based PV system can prevent the domino effect and reduces the cost per harvested watt by up to 20% over the life of the system.